

MODEL 700

WURLITZER ELECTRONIC PIANO SERVICE MANUAL

PLEASE INSERT THIS IN THE BACK OF YOUR
PRESENT WURLITZER ELECTRONIC PIANO
SERVICE MANUAL

WURLITZER CONSOLE ELECTRONIC PIANO - MODEL 700

SERVICE MANUAL SUPPLEMENT

Introduction

The Wurlitzer Console Model 700 Electronic Piano was designed and developed in Wurlitzer's Mechanical and Electronic Engineering Laboratories to supplement the very popular Model 120 Portable Electronic Piano. It is an entirely new design of the fascinating Electronic Piano, a new concept in keyboard instruments, with a compact and attractive console case into which has been built all the many desirable exclusive features found only in these Wurlitzer Electronic Pianos.

The purpose of this Service Manual is to serve as a guide in the proper servicing of these instruments. The manual is of loose leaf construction so it can be inserted in the cover of the Electronic Piano Service Manual.

The pages and illustrations in this supplement all have "700" as the prefix so as to avoid confusion with the Model 112 and 120 section.

In order to avoid repetition and to keep the Service Manual compact when items referring to the Model 700 are the same as those which apply to the Model 112, 120, or a Conventional Wurlitzer Piano, there will be a reference to certain pages of those manuals.



Fig. 700-A

SPECIFICATIONS OF THE WURLITZER ELECTRONIC PIANO MODEL 700

Width - 40 $\frac{1}{2}$ "	115 Volts, A.C.
Depth - 18"	60 Cycle
Height - 35"	AC Wattage Consumption: 60

SPECIFICATIONS FOR BENCH FOR WURLITZER ELECTRONIC PIANO
MODEL 700

Height - 19 $\frac{1}{2}$ "
Width - 13"
Length - 22"

PREPARATION OF THE MODEL 700 WURLITZER ELECTRONIC PIANO
FOR SALE

See Page 2 of Model 112 Section of the Service Manual.

1. Unpack and check as outlined on Page 2 of the Model 112 Electronic Piano Service Manual.
2. Sometimes, during shipment, dirt and foreign materials become lodged between the reeds and the pickups causing noisy amplification. It can be easily corrected in the following manner:
 - a. First turn the volume completely down. Starting from the bass end, strike each key, with a normal blow, three times. It may be necessary to repeat this procedure several times.
 - b. If this does not take care of the noise, please refer to the Model 112 Electronic Piano Service Manual, Page 7, under Tone Producing Principle, and familiarize yourself with the contents. Remove the top of the piano, (refer to Page 700-4, Fig. 700-B.) Place a piece of white paper between the hammer (25) and the reed (26) and turn a flashlight on the paper. This enables you to see any foreign material that may still be on the reed or pickup (9). You may find that the reed is "off center" which will show up by having more light on one side than the other. This latter condition can be corrected by loosening the reed screw and re-centering the reed. Be sure the reed screw is firmly tightened after the reed has been centered.



Fig. 700-B

REMOVING THE TOP

The top is fastened to the case by two screws. See Fig. 700-B. Remove the two screws and slide the top forward.

(It is necessary to remove the back to get to the screws that fasten the top on the very early Model 700 Pianos.)

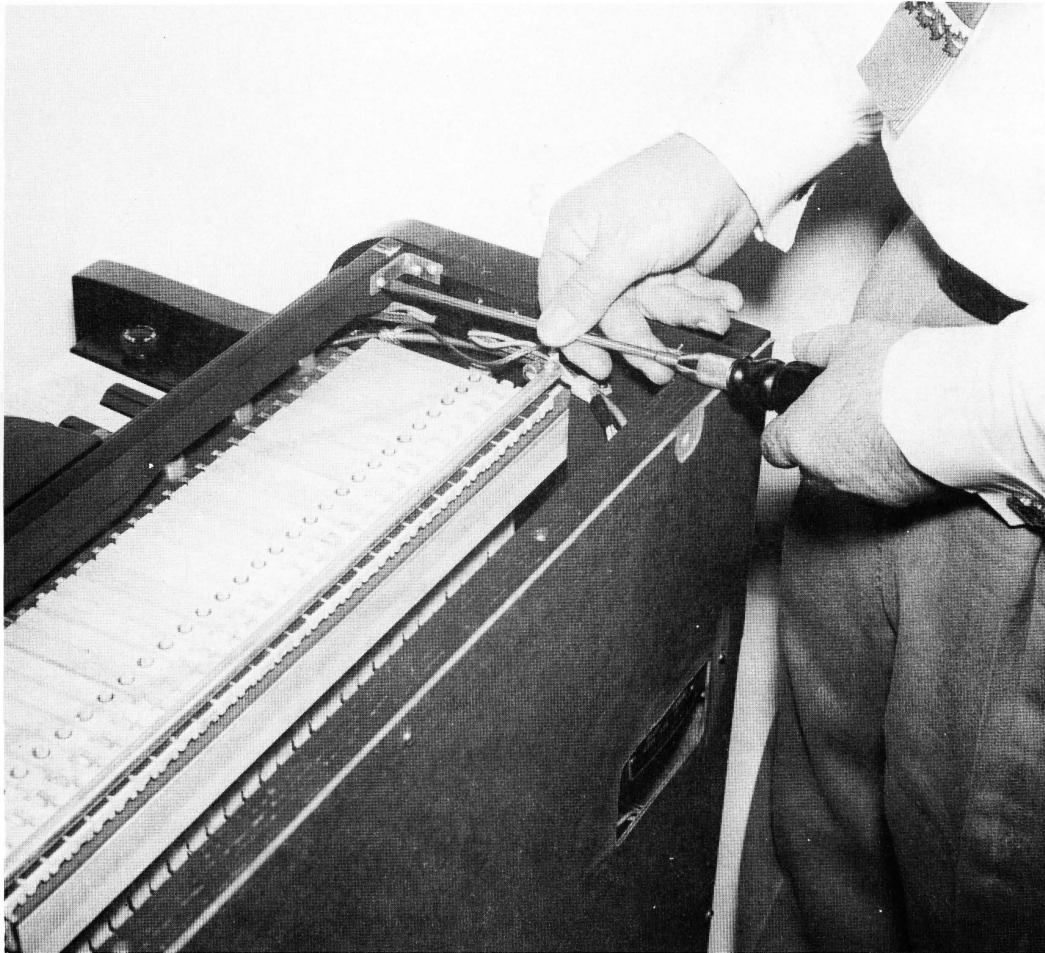

Fig. 700-C

REMOVING NAME RAIL, AND MUSIC PANEL

The name rail is fastened with two screws, (see Fig. 700-c.) Remove these screws and carefully remove the name rail so as not to scratch the Rim Arms.

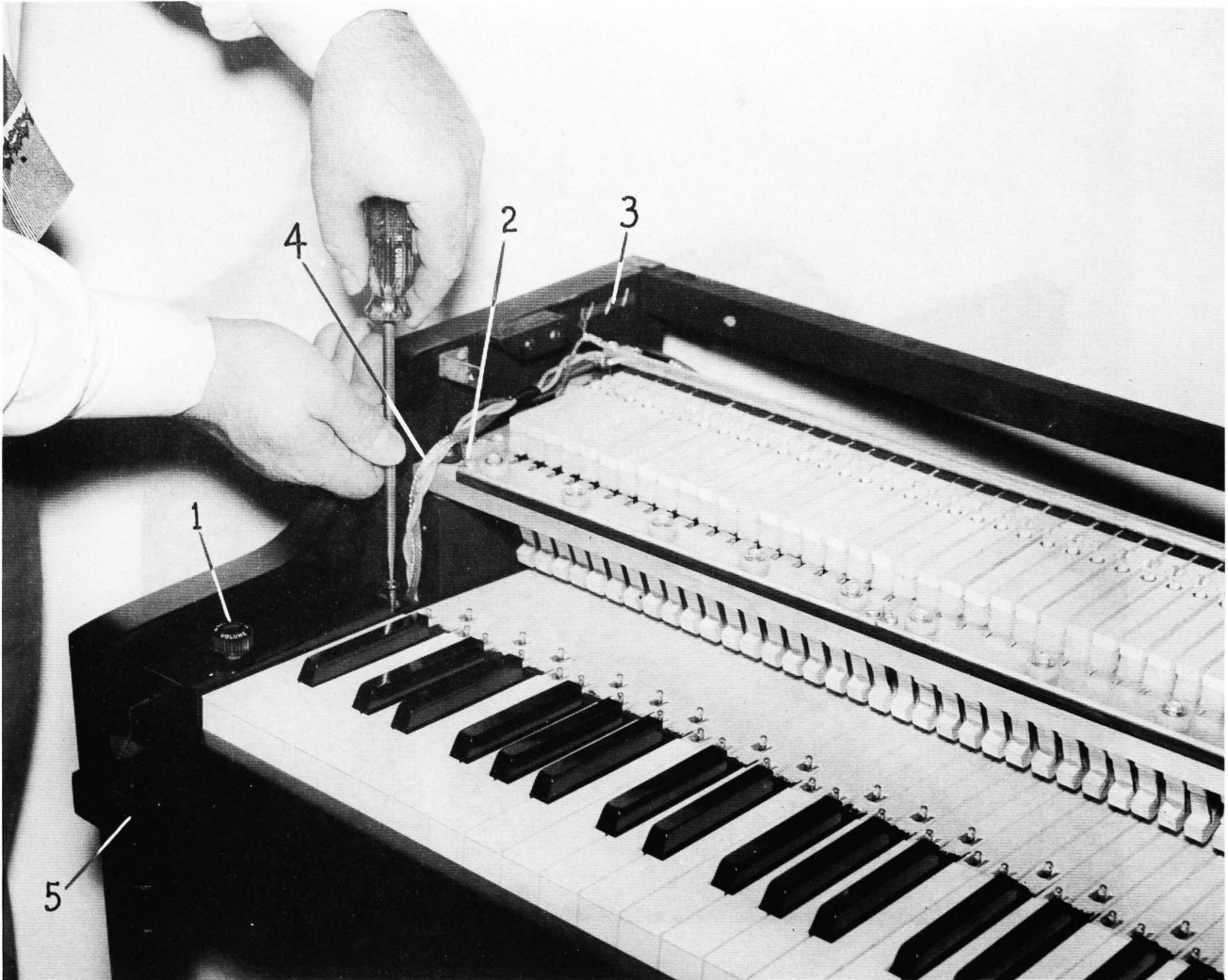

Fig. 700-D

1. On-Off Switch and Volume Control
2. Input Cable
3. Ground Cable
4. Control Panel Cable
5. Control Panel Mounting Screw

REMOVING CONTROL PANEL

To remove the Control Panel, remove the screw as shown in Fig. 700-D. Also remove the screw fastening the control panel, through the bottom of the key bed. (Labeled "5" in Fig. 700-D.)

CHECKING THE AMPLIFICATION SYSTEM

1. Remove the back.
2. Inspect amplifier to see if all the tubes are mounted securely in their sockets. These tubes are standard types and should be available locally if replacement is ever necessary. (Location of tubes shown in Figures 700-E and 700-R.)
3. Check to see that the following cables are plugged in tightly as shown in Figure 700-E.
 - a. Piano input cable.
 - b. Control panel cable.
4. Fuse: Check 1 amp fuse (Slo-Blo) as shown in Figures 700-E and 700-R.
5. A.C. Cord: This cord is a one-piece molded line cord which fits the receptacle on the back of the piano as shown in Fig. 700-E.

WARNING! This instrument operates only
on 110 Volts, 60 cycle.
6. Switch and volume control: The line switch is on the keyblock control panel located in the left key block. When the knob is turned counter-clockwise as far as possible, it is in the "off" position. Rotating the knob clockwise turns the amplifier on and the pilot light will glow. The amplifier is at full volume when this knob is turned to the extreme clockwise position.
7. The pilot lamp is located on the bass end of the lower front panel. The earphone jack is located just above the pilot lamp. (See Figure 700-A.)

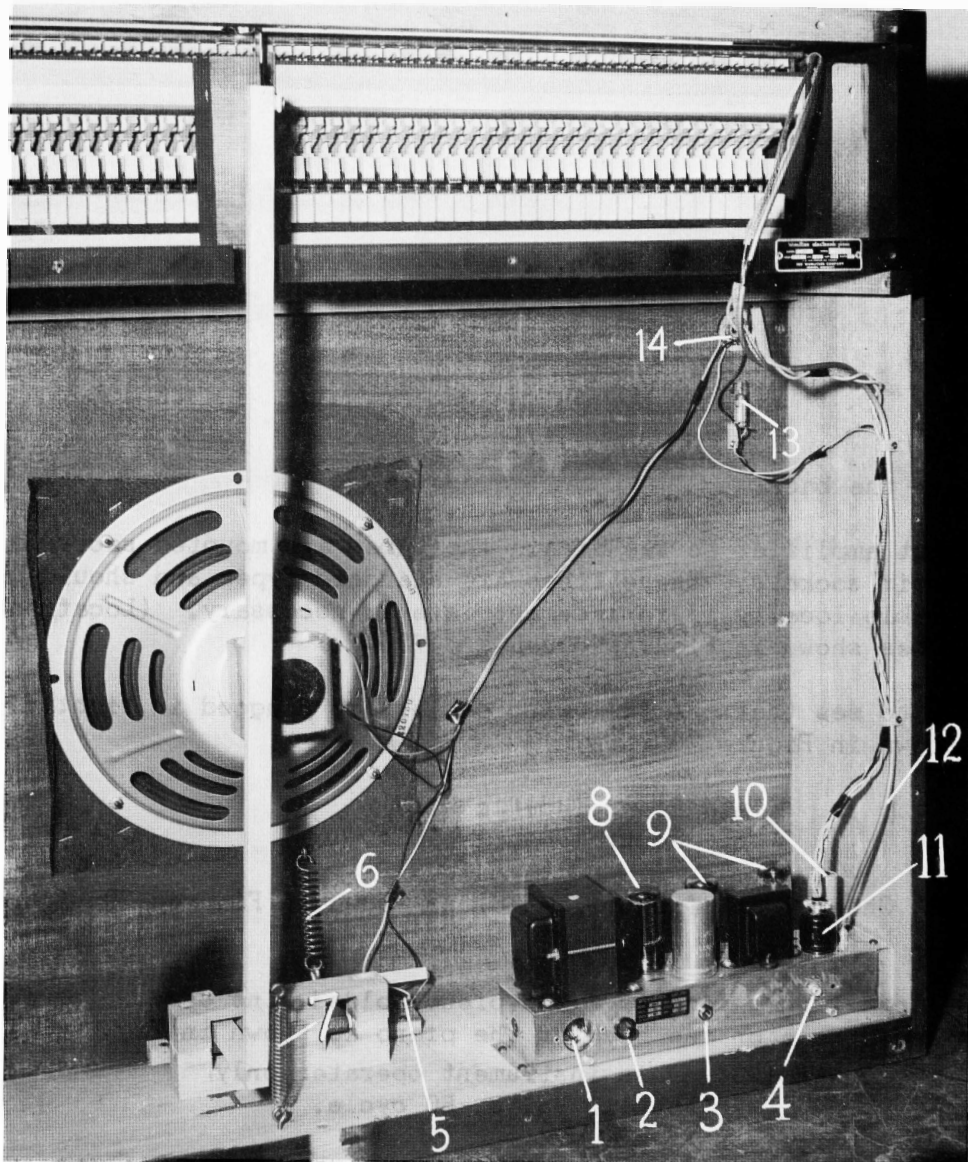
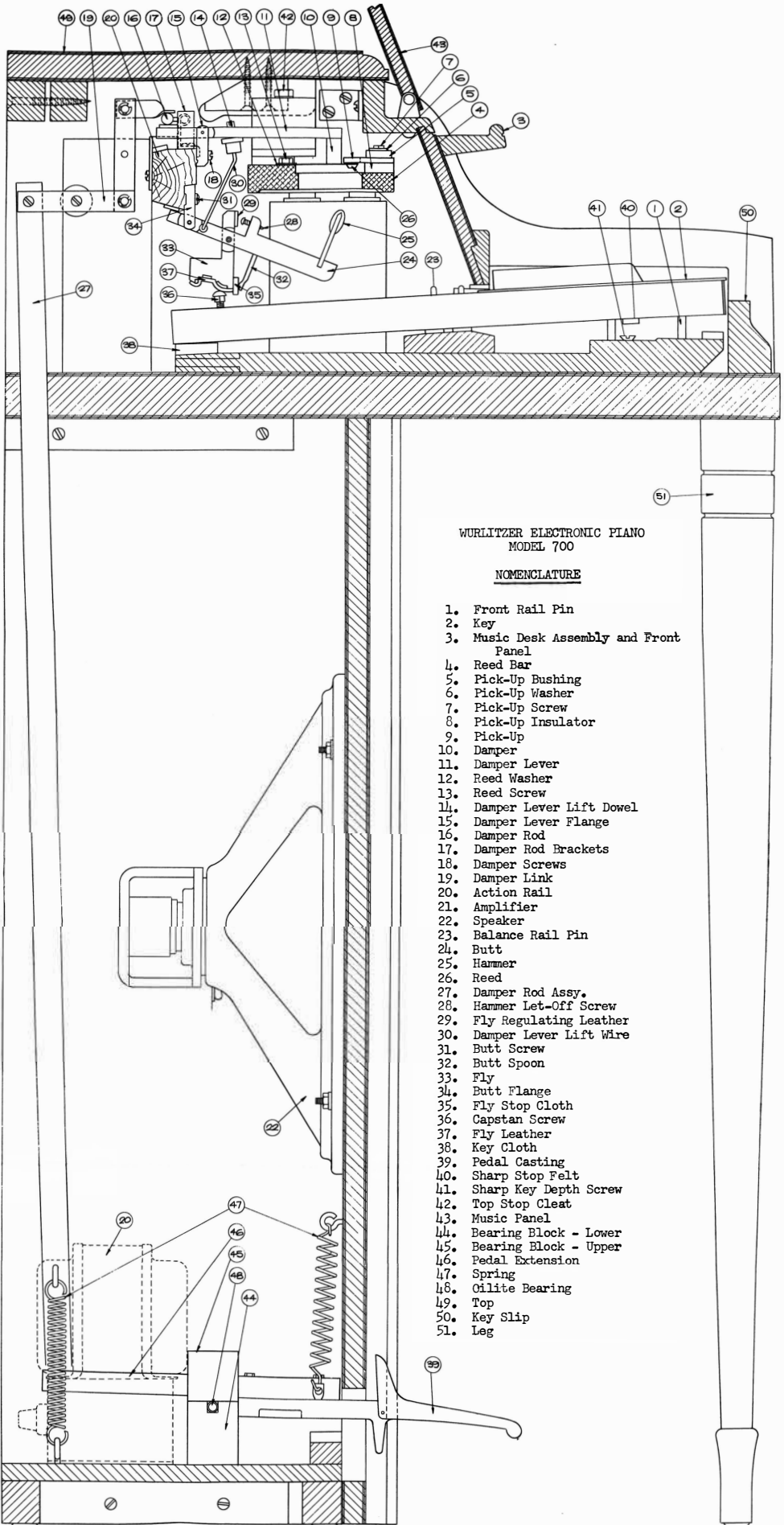

Fig. 700-E

- | | |
|----------------------------|------------------------|
| 1. Line Cord Receptacle | 8. 5Y3 GT Tube |
| 2. 1 Amp. S10-B10 Fuse | 9. 6V6 GT Tubes |
| 3. External Speaker Jack | 10. 12AX7 Tube |
| 4. Record Player Input | 11. Control Cable Plug |
| 5. Soft Pedal Switch | 12. Piano Input Plug |
| 6. Soft Pedal Spring | 13. Pilot Lamp |
| 7. Sustaining Pedal Spring | 14. Earphone Jack |

 TONE PRODUCING PRINCIPLE

See diagram and explanation on Page 7 of Model 112 Section.



WURLITZER ELECTRONIC PIANO
MODEL 700

NOMENCLATURE

1. Front Rail Pin
2. Key
3. Music Desk Assembly and Front Panel
4. Reed Bar
5. Pick-Up Bushing
6. Pick-Up Washer
7. Pick-Up Screw
8. Pick-Up Insulator
9. Pick-Up
10. Damper
11. Damper Lever
12. Reed Washer
13. Reed Screw
14. Damper Lever Lift Dowel
15. Damper Lever Flange
16. Damper Rod
17. Damper Rod Brackets
18. Damper Screws
19. Damper Link
20. Action Rail
21. Amplifier
22. Speaker
23. Balance Rail Pin
24. Butt
25. Hammer
26. Reed
27. Damper Rod Assy.
28. Hammer Let-Off Screw
29. Fly Regulating Leather
30. Damper Lever Lift Wire
31. Butt Screw
32. Butt Spoon
33. Fly
34. Butt Flange
35. Fly Stop Cloth
36. Capstan Screw
37. Fly Leather
38. Key Cloth
39. Pedal Casting
40. Sharp Stop Felt
41. Sharp Key Depth Screw
42. Top Stop Cleat
43. Music Panel
44. Bearing Block - Lower
45. Bearing Block - Upper
46. Pedal Extension
47. Spring
48. Oilite Bearing
49. Top
50. Key Slip
51. Leg



Fig. 700-J

CHECKING THE BAR AND REEDS

The reed bar in the Electronic Piano must float freely on the two rubber washers located at each end of the bar. Be sure the two large bar mounting screws on each end are NOT screwed down tight against the rubber washers. There should be at least 1/64" space between the head of the screws and the rubber washers. (See Fig. 700-G.)

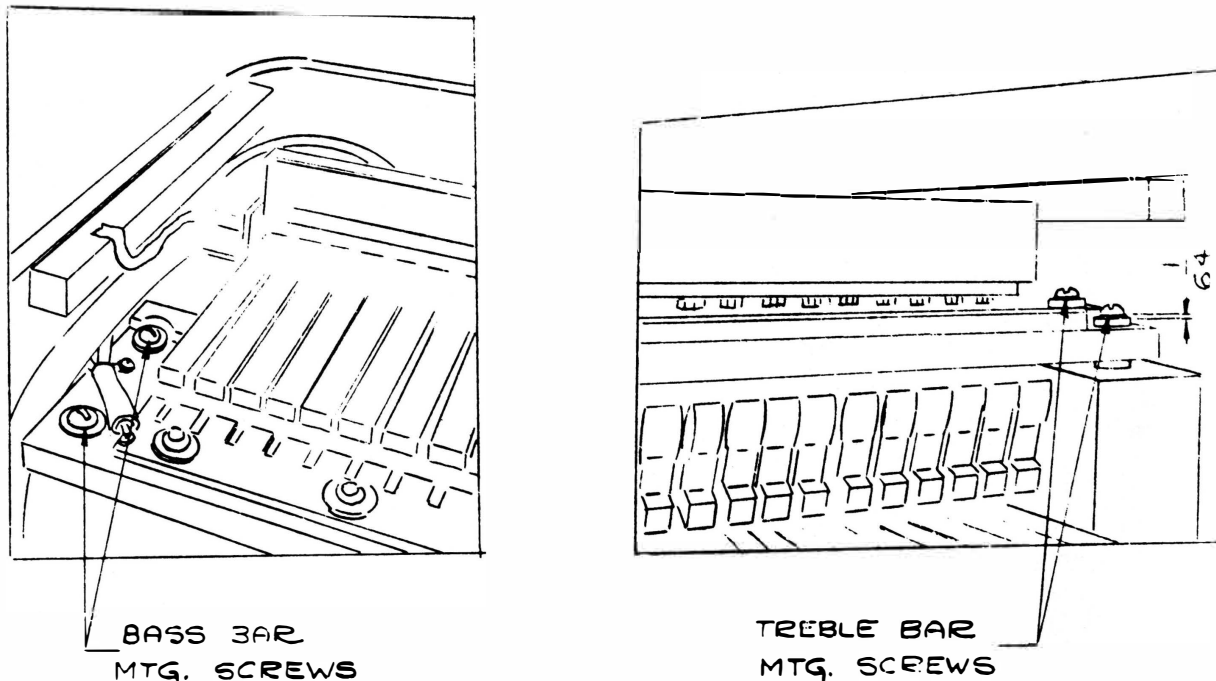

Fig. 700-G

IMPORTANT - A new scale of reed dimensions, differing from the 112, has been incorporated into the Models 120 and 700; therefore, all the reeds are not interchangeable with reeds of former models. For further instruction, see Page 700-29.

KEY AND ACTION REGULATION

Like the conventional piano, the regulation of the keys and action is very important, and should only be undertaken by a tuner-technician or a trained service man.

In the event excessive moisture in the air causes sluggish keys or action centers, they should be corrected according to the instructions given in the Wurritzer Piano Service Manual. "Ease Keys" is described on Pages 4 and 7, and "Shrinking Action Centers" is explained on Pages 12 and 16 of that manual. Before shrinking action centers, turn the instrument on for several hours. The heat from the amplifier may dry out the action sufficiently to make shrinking unnecessary.

REGULATING PROCEDURE

1. LEVEL AND EASE KEYS

If key leveling is necessary, it can be done by removing or adding paper punchings under the felt washers on the balance rail. (See Page 11 of Model 112 section.)

2. KEY DEPTH

The proper key depth is 13/32" measured at the front of the white keys. If the key height is correct and the key depth is shallow, it may be increased by removing material from the bottom of the front of the white key. (See Fig. 700-R, for method of removing key.) If the key depth is too deep, paper punchings of the required thickness may be glued to the bottom surface of the front of the key.

NOTE - It is best to wait until the hammer let-off has been adjusted before setting the key depth of the sharps.

If all the keys have a shallow depth, it may be better to build up the balance rail either with paper punchings under the keys, or shims under the balance rail.

3. ADJUST CAPSTAN SCREWS (See Fig. 700-H)

The capstan screws are adjusted so there is 3-13/16" from the bottom of the key frame to the tips of the hammers. The hammer tip line will be even when capstan screws are properly adjusted. They are not at the point of lost motion as was the case in the Model 112.

4. LET-OFF ADJUSTMENT (See Fig. 700-I and 700-J)

The hammer should let off 1/16" from the reed in the treble and 1/8" in the bass. This is the ideal adjustment for light touch.

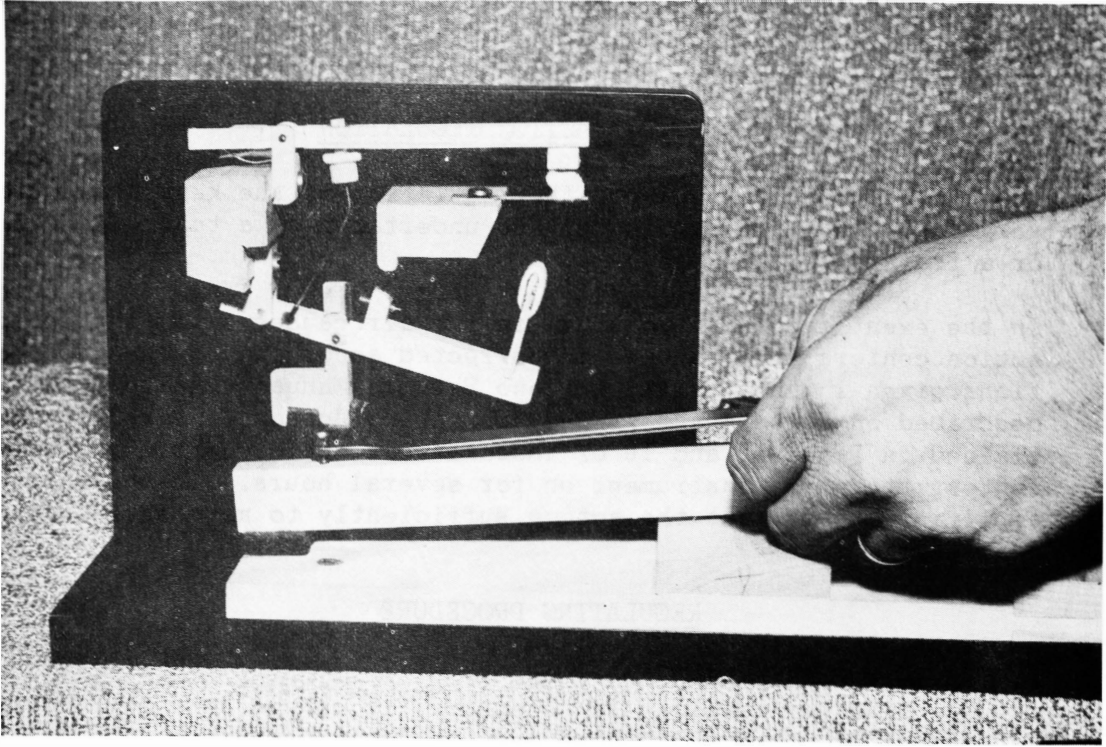

Fig. 700-H Adjusting Capstan Screw

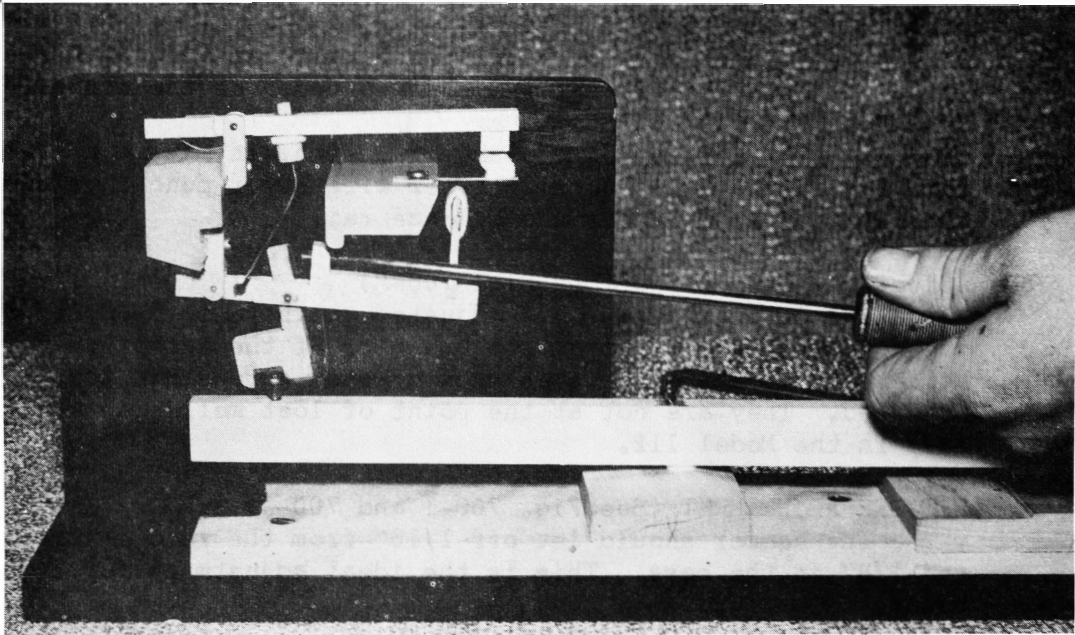
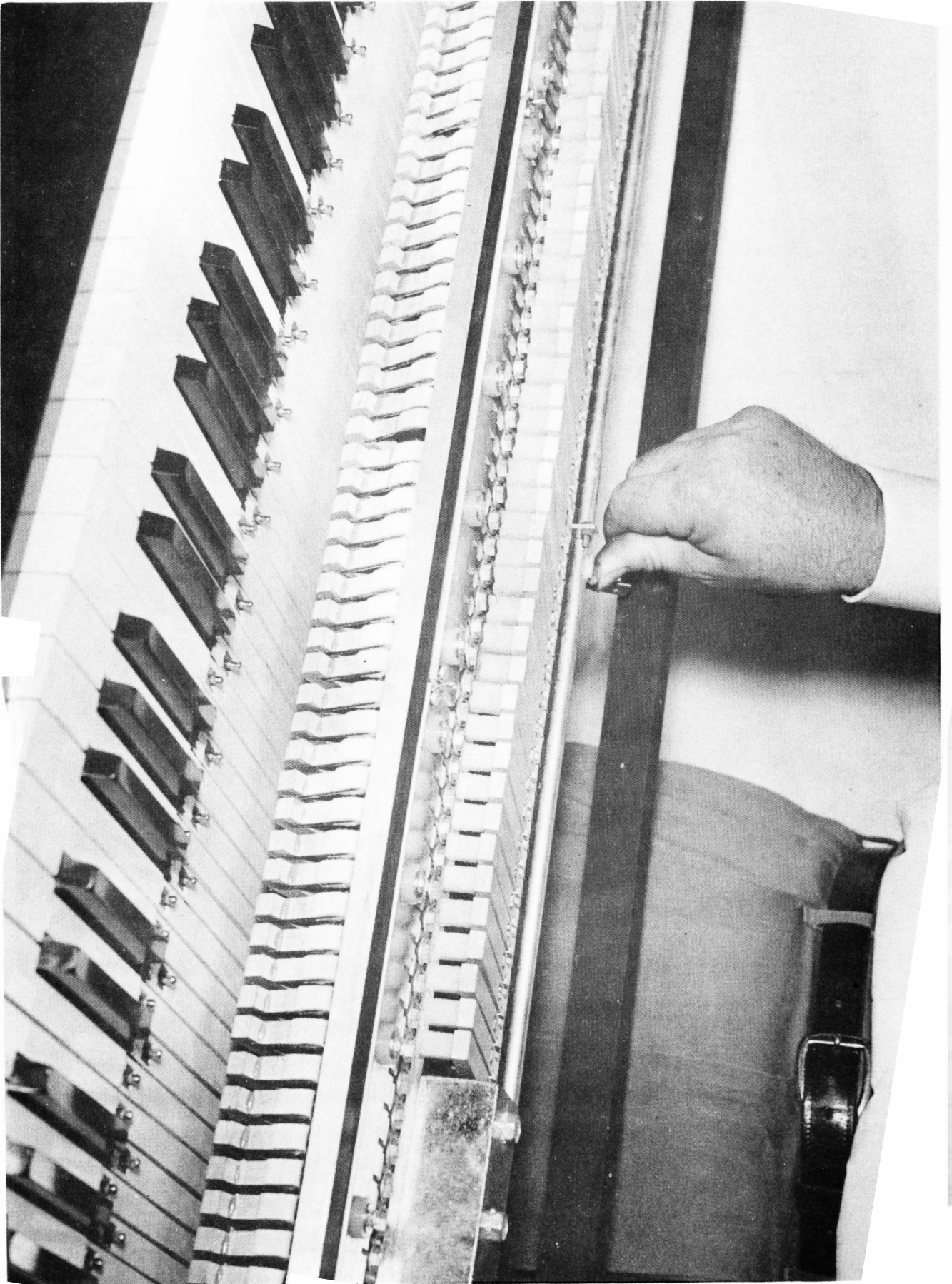

Fig. 700-I Adjusting Let-Off Screw



Fig. 700-R



File 700-2

IMPORTANT: Experience has proven the felts will pack on a new instrument, so the factory is setting the let-off $1/16''$ greater than the figures in the above paragraph.

This allows about $1/32''$ after-touch or movement of the key after the hammer lets off. The let-off is adjusted by the regulating screw as shown in Figures 700-I and 700-J.

NOTE: The let-off screwdriver used for regulation is equivalent to item No. 4102 (Page 23) in Schaff Piano Supplies Catalog.

If the screw is turned clockwise too far, it will cause the hammer to let off too soon and the piano will not function properly with a light touch. Also, excessive after-touch will occur. If the screw is turned counter-clockwise too far, the hammer will not let off and will block against the reed. This results in little or no after touch.

If some of the notes have excess after-touch, the hammer will let-off, check back, and then rise high enough to block on the reed. This can be corrected by gluing one half ($1/2$) of a paper front rail punching of the desired thickness to the bottom of the front of the white key.

NOTE; If the whole action is this way, check paragraph on key depth (Paragraph 2) and capstan screws (#3) before proceeding.

5. ADJUSTING SHARPS

The key depth and after-touch of the sharps are adjusted by the screw under the front of each sharp. Turning this screw clockwise allows greater key depth and after touch; turning it counter-clockwise allows less key depth and less after-touch.

6. SPOON ADJUSTMENT (Fig. 700-K)

The butt spoon (Item 32, Fig. 700-F,) has been factory-set and should not require adjustment. The spoon is bent out just far enough so the capstan screw, (Item 36, Fig. 700-F,) will escape to the fly leather, (Item 37, Fig. 700-F.)

The proper setting of the butt spoon is when the spoon clears the fly stop cloth, (Item 35, Fig. 700-F,) by $1/64''$ after the key is fully depressed and let-off has been obtained. Proper or full check back will result.

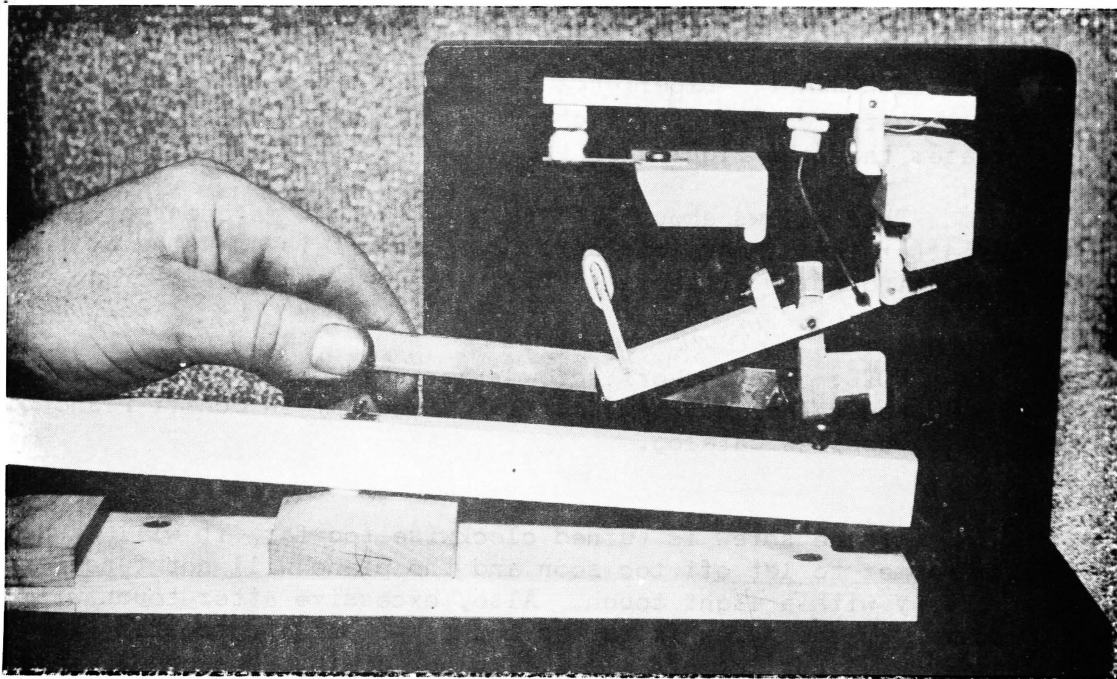

Fig. 700-K Adjusting Spoon

Improper setting of the fly spoon is when the spoon does not clear the fly stop cloth after the key is fully depressed. Full check back will not result and the capstan screw will not bottom on the fly leather.

NOTE: A small circular mirror with a handle, such as dentists use is handy for checking spoon regulation and can generally be purchased from radio supply houses.

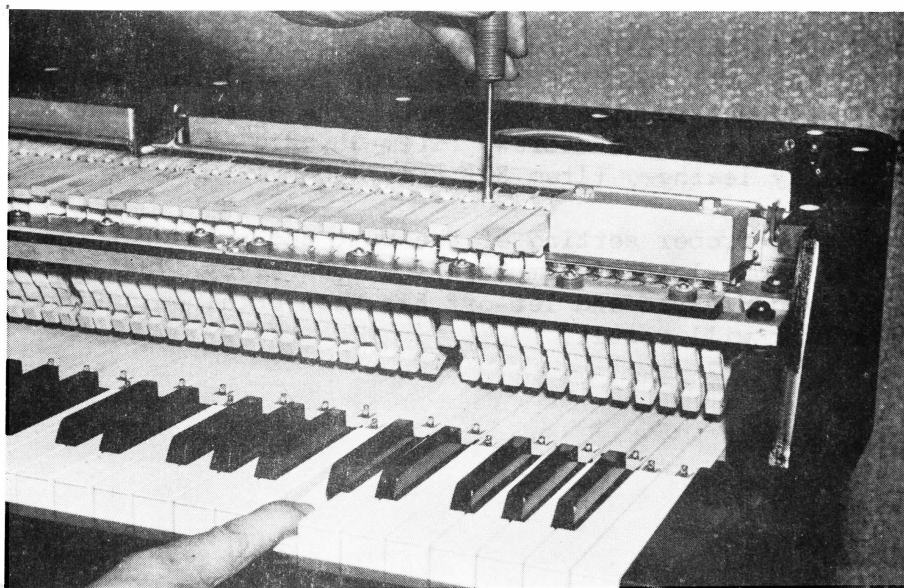

Fig. 700-L Damper Adjustment

7. DAMPER ADJUSTMENT

The dampers are adjusted by the damper lever lift dowel which protrudes through the damper levers. See Fig. 700-L. When the key is fully depressed, the damper should be lifted $3/16$ " from the reed. Turning the slotted dowel counter-clockwise causes the damper to be lifted higher.

When the damper link (Item 19, Page 700-9,) is depressed, all the dampers lift from the reeds at once. (See Fig. 700-Q.) This should be followed if it is ever necessary to remove the reed bar.

TONE REGULATING (OR VOICING)

Tone regulating of the Wurlitzer Electronic Piano is accomplished in the same manner as in a conventional piano and should only be done by a tuner-technician.

STRIKING POINT

The striking point of the hammers to the bar is very important, just as it is in a conventional piano. The striking point is properly set at the factory and should require little or no adjustment in the field.

In the event the striking point does need adjustment, it is more likely to be in the treble. If some of the treble notes sound "dead" or "woody", first check to be sure the two large bar mounting screws are not down tight against the rubber mounting washers, (see Fig. 700-G.) Then remove the rear large screw and loosen the front one. Turn the instrument on and while striking the treble keys, move the treble end of the bar slightly forward and backward until the maximum volume and desired tone is reached. If this location of the bar is such that the rear screw hole in the bar mounting block does not coincide with the center of the rear mounting hole in the bar, plug the original hole in the mounting block and re-drill a hole for the rear screw. The front mounting hole in the bar is slotted and allows for adjustment. Before putting screws in, be sure the proper washers or spacers are in place. Also remember there should be $1/64$ " clearance between the heads of the screws and the rubber mounting washers.

If there are only one or two treble notes that do not sound right because of improper striking point, the hammers can be burned either in or out by applying heat with a soldering iron to the shank or moulding of the hammer, and at the same time forcing the hammer in the desired direction. (See Fig. 700-M).

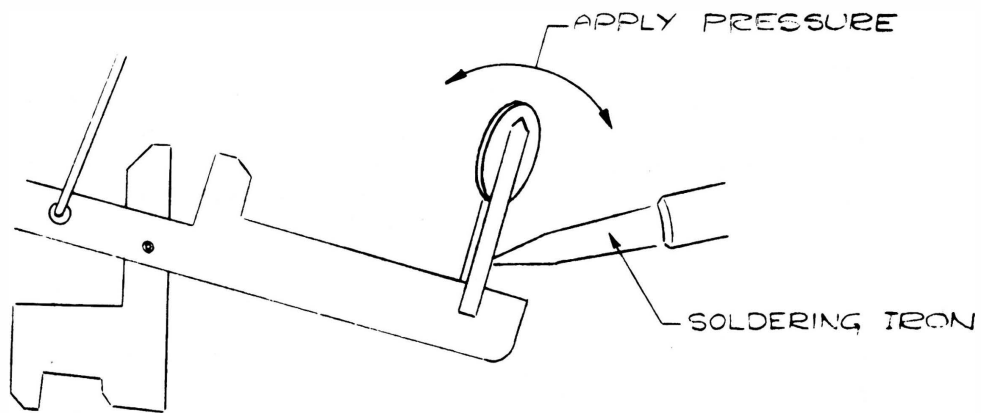

Fig. 700-M (Burning Hammers)

BLOCKING HAMMERS

Blocking hammers can be caused by any one of four things, or a combination of them:

- a. Improper capstan screw adjustment.
- b. Improper regulating screw adjustment.
- c. Excessive key depth.
- d. Excessive after touch.

TONES NOT PRODUCED BY A LIGHT TOUCH

This condition is caused by hammers letting off too quickly or too far from the reeds.

ADJUSTING AND CHECKING REEDS

See Page 12 of the Model 112 Service Manual. The procedure is the same except that the Model 700 does not have a shield over the reeds. The interiors of the case and top are covered with an electrostatic shield paint, which acts as a shield.

ORDERING REPLACEMENT REEDS

The reeds on the Model 700 have been made stronger and should give very good service under any normal playing conditions. However, if it is necessary to order replacement reeds, please comply with the following instructions to insure receiving the proper reeds:

If reeds are desired for the 26th (A#) and the 46th (F#) notes on the Electronic Piano, order one reed No. 586-26-A# and one reed No. 586-46-F#. (See Reed Chart, Page 700-29.)

Using the Reed Chart on Page 700-29 of this Service Manual, list the part number and name of the note to designate the reed, which will aid our Service Department in filling your order promptly and correctly.

IMPORTANT: All replacement reeds are tuned flat intentionally, for it is simple to file or scrape a little lead off the tips to bring them into proper tune after installing them on the bar. (See "Adjusting and Checking Reeds" on Page 12 of the Model 112 section for tuning instructions.)

CLEANING KEYS

See Page 12 in Model 112 Service Manual.

AMPLIFIER

The amplifier is shown in Figs. 700-E, 700-P, and on the schematic wiring diagram, Fig. 700-O, which also shows the value of component parts. Voltages are measured on a vacuum tube voltmeter (VTVM), and are indicated on the print. The piano volume control and line switch is one unit and it is located in the left keyblock. (Note: Fig. 700-N is a schematic drawing of control panel.) All tubes should be checked before working on the amplifier.

Any competent radio service man should be able to check the amplifier with the aid of the schematic drawing, (Fig. 700-O.)

EARPHONES

The phone jack is located in the upper left corner of the lower front panel. The speaker is cut out when the earphones are plugged in. Any high or low impedance earphones will work satisfactorily. A second set of earphones may be plugged into the jack marked "speaker" if desired. See Fig. 700-E. The regular volume control in the left keyblock controls the volume for both of these jacks.

EXTERNAL SPEAKER

Any external low impedance speaker may be plugged into the jack marked "speaker" on the back of the case. (See Fig. 700-E.) Both the speaker in the unit and the external speaker will play when the external speaker is plugged into the "speaker" jack. If the external speaker is plugged into the phone jack, it cuts out the speaker in the piano. In either case the regular piano volume knob controls the volume of the speakers.

EXTERNAL AMPLIFICATION

The amplifier in the Model 700 Electronic Piano may be used as a pre-amplifier to drive a higher powered amplifier by plugging into either the phone jack in the left keyblock, (which will cut out the regular piano speaker,) or into the external speaker jack in the back of the case, which permits the piano speaker to operate also.

Wurlitzer now has a specially constructed external amplifier, Model 920, which contains an 18 Watt amplifier driving a 12" concert speaker. It comes equipped with a 3-speed tremolo control, bass and treble controls, as well as jacks for other instruments or micro-phones.

RECORD PLAYER JACK

Any high impedance phonograph pickup (record player) may be fed into the record input jack of the Model 700. (See Fig. 700-E.) The volume of the record player may be controlled by the regular volume control on the Electronic Piano.

SERVICE DEPARTMENT

Please refer to the Wurlitzer Piano Service Manual for complete instructions regarding the handling of service for the Wurlitzer Electronic Piano. All Wurlitzer Electronic Piano service inquiries should be directed to the SERVICE DEPARTMENT, THE WURLITZER COMPANY, DE KALB, ILLINOIS.

FILING CLAIMS WITH CARRIERS

Please refer to Page 26 of the Wurlitzer Piano Service Manual.

IMPORTANT!

Written authorization must be obtained from the Service Department, The Wurlitzer Company, DeKalb, Illinois, before returning any Electronic Piano for repair. No claim for damage that has occurred can be considered by the carrier or by the Wurlitzer Service Department unless a full and complete explanation has been noted on the shipping papers.

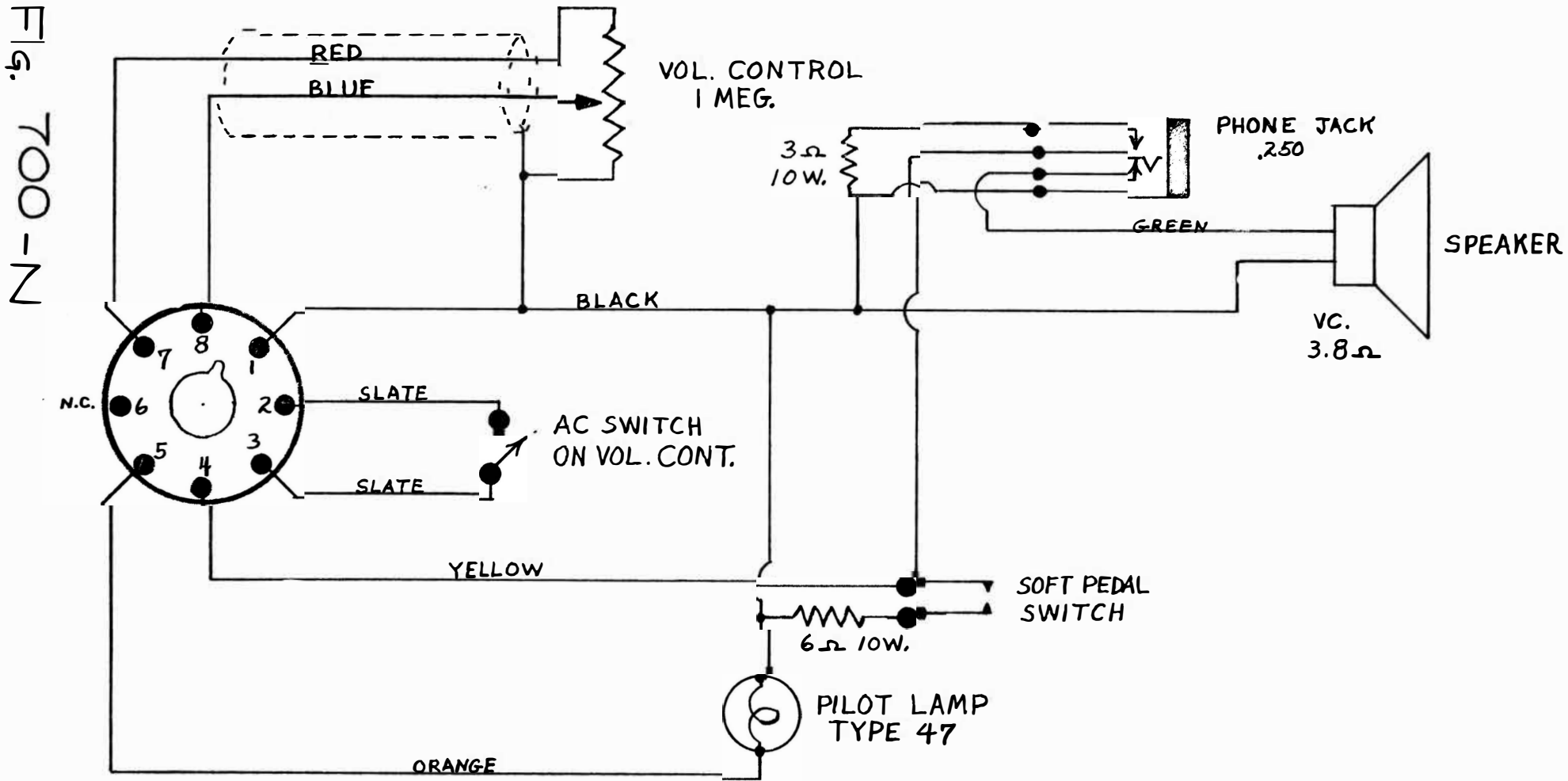

MODEL 700 CONTROL PANEL AND SPEAKER

FIG. 700-N

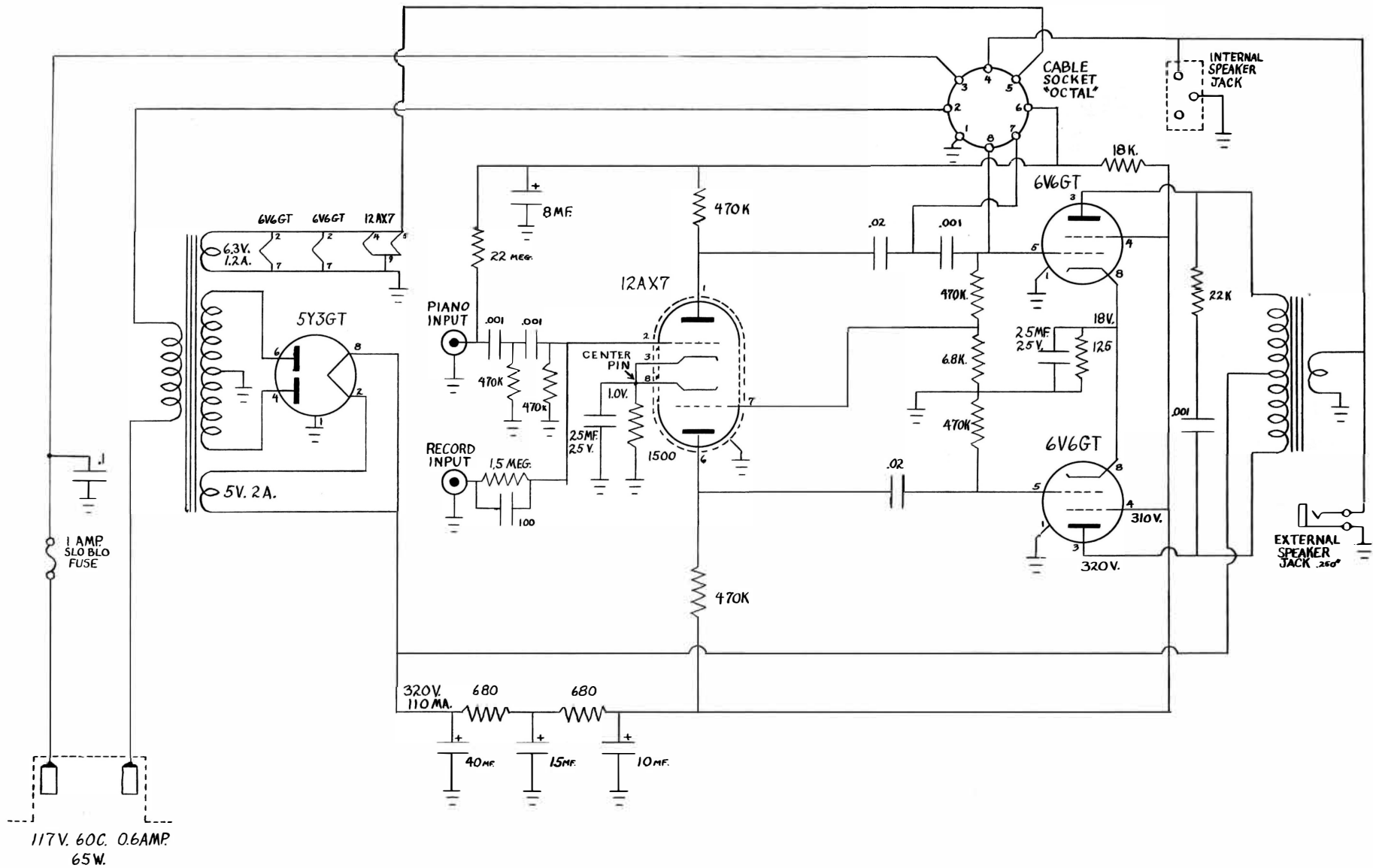

WURLITZER ELECTRONIC PIANO MODEL 700 AMPLIFIER EP-600-3

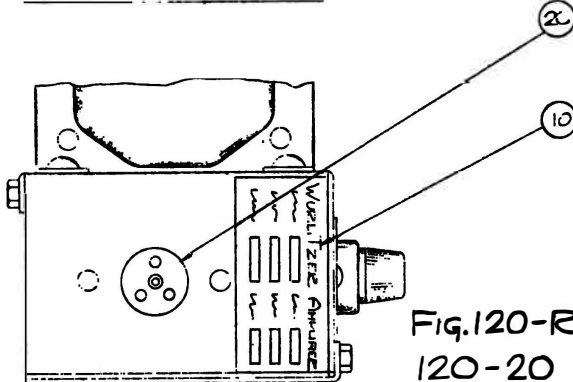
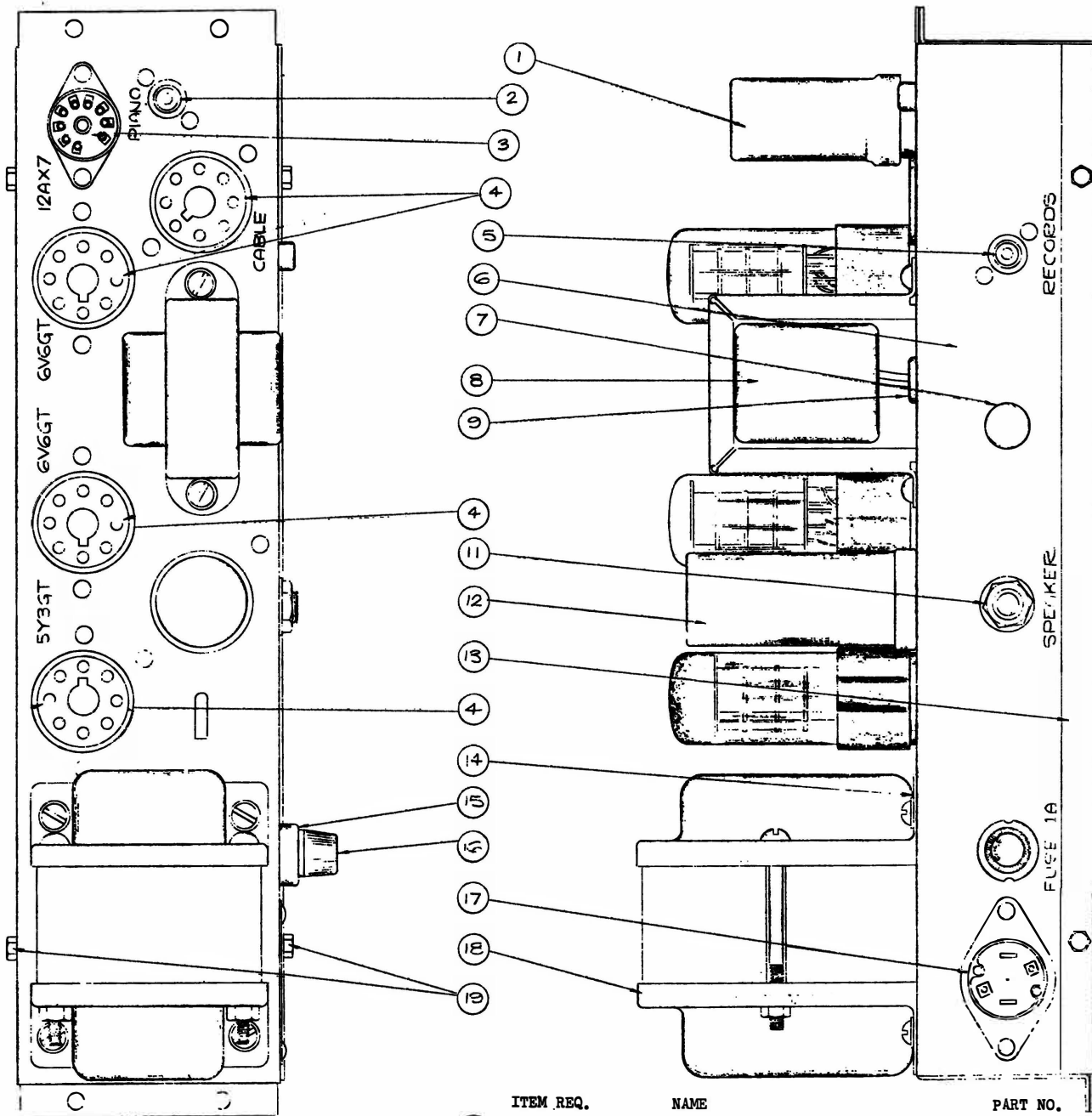

Fig. 120-R
120-20

ITEM	REQ.	NAME	PART NO.
1	1	TUBE COVER	EP-623a
2	1	PIANO JACK	EP-372a
3	1	NOVAL SOCKET	EP-614a
4	4	OCTAL SOCKET	EP-366a
5	1	RECORD JACK	EP-372a
6	1	CHASSIS TOP	EP-610c
7	1	HOLE PLUG	EP-633a
8	1	TRANSFORMER OUTPUT	EP-613c
9	1	GROMMET	EP-374a
10	1	SERIAL NO. PLATE	EP-615a
11	1	SPEAKER JACK	EP-369a
12	1	DRY ELECTROLYTIC 4 SECT.	EP-390a
13	1	CHASSIS BOTTOM	EP-611a
14	1	GROMMET	EP-377a
15	1	FUSE HOLDER	EP-378a
16	1	FUSE	EP-379a
17	1	A.C. LINE	EP-622a
18	1	TRANSFORMER POWER	EP-612c
19	4	1/4 #8 HEX HD. SHT. METAL SCR.	
20	1	SPEAKER SOCKET	EP-368a

MODEL 700 WURLITZER ELECTRONIC PIANO

PART NAMES AND NUMBERS

NOTE: Specify Finish on Case Parts

<u>Item</u>	<u>Name</u>	<u>Part Number</u>
1.	Front Rail Pin	Sub Assy of EP-690d
2.	Key	" " " "
3.	Music desk & Front Panel Assy.	
	Music Desk	EP-1026
	Head Rail	EP-1011
	Music Panel Rail	EP-1022
	Drop Rail	EP-1010
4.	Reed Bar (complete)	EP-671
5.	Pick-up Bushing	EP-589
6.	Pick-up Washer	EP-721
7.	Pick-up Screw	EP-715
8.	Pick-up Insulator	EP-593
9.	Pick-up	
	Bass	EP-591
	Middle	EP-590
	Treble	EP-592
10.	Damper	
	Treble (11 req.)	EP-979
	Bass (42 req.)	EP-980
11.	Damper Lever	Sub Assy of EP-690d
12.	Reed Washer	Part of Reed Screw EP-957
13.	Reed Screw	EP-957
14.	Damper Lift Dowel	Sub Assy of EP-690d
15.	Damper Lift Flange	" " " "
16.	Damper Rod	" " " "
17.	Damper Rod Brackets	" " " "
18.	Damper Screws	" " " "
19.	Damper Link	EP-1078
20.	Action Rail	Sub Assy of EP-690d
21.	Amplifier	EP-600
22.	Speaker	EP-1031
23.	Balance Rail Pin	Sub Assy of EP-690d
24.	Butt	" " " "
25.	Hammer (64 req.)	Sub Assy of set EP-503b, specify note needed.
26.	Reed	Set EP-586b, see Page 29 for Individual Reed Nos.
27.	Damper Rod Assy.	EP-1076
	Damper Rod	EP-1036
	Screw Eye	EP-1079
	Rubber Grammet	EP-1047
	Pin	EP-1048
28.	Hammer Let Off Screw	Sub Assy of EP-690d
29.	Fly Regulating Leather	" " " "
30.	Damper Leather Lift Wire	" " " "

Part Names and Numbers, Cont'd

<u>Item</u>	<u>Name</u>	<u>Part Number</u>
31.	Butt, Screw	Sub Assy of EP-690d
32.	Butt, Spoon	" " " "
33.	Fly	" " " "
34.	Butt Flange	" " " "
35.	Fly Stop Cloth	" " " "
36.	Capstan Screw	" " " "
37.	Fly Leather	" " " "
38.	Key Clth	" " " "
39.	Pedal	EP-1096
40.	Sharp Stop, Felt	Sub Assy of EP-690d
41.	Sharp Key Depth Screw	" " " "
42.	Top Stop Cleat	EP-1093
43.	Music Panel	EP-951c
44.	Lower Bearing Block	EP-1025
45.	Upper Bearing Block	EP-1024
46.	Pedal Extension	EP-1034
47.	Pedal Springs	EP-1071 & EP-1072
		Note: If Pedal Spring replacement is required, it is suggested that both springs be replaced, because existing spring is probably weak.
48.	Oilite Bearing	EP-250
49.	Top	EP-1053
50.	Key Slip	EP-1007
51.	Leg	EP-1054

Description and part numbers of miscellaneous parts not shown in drawings.
(Be sure to specify finish on all wood parts.)

Key Block (right)	EP-1028
Key Block (left - has hole for control)	EP-1090
Bench	EP-1055
Top	EP-1039
Leg	EP-1040
Stop Assy.	A-9020
Stop Assy. (Oak)	9-133
Hinges	7-139000
Glide	EP-404
Rubber Head Nails	7-131-005
Rubber Head Nails (Oak)	7-131-006
Grille Cloth (Ebony)	EP-1099-2
(Oak)	EP-1099-3
(Walnut & Mahogany)	EP-1099-1
Back	EP-1027
Power Supply Cord (brown)	EP-347-2
(black)	EP-347-1
Volume Control and Switch	EP-627b
Pilot Light Socket	EP-1052

Part Names and Numbers, Cont'd

Soft Pedal Switch	EP-1051
Speaker Plug (3-prong)	EP-978
Soft Pedal Resistor (6 ohms wire wound)	EP-629-2
Volume Control Knob (Mahog. & Walnut)	EP-625-1
(Ivory)	EP-625-2
(Ebony)	EP-625-3
Headphone Jack	EP-370
Resistor for Phone Jack (3 ohm wire wound)	EP-629-1
Jewel (Pilot Light)	19343
Glide, Leg	EP-404a

MODEL 700 WURLITZER ELECTRONIC PIANO

AMPLIFIER PARTS LIST

<u>Name</u>	<u>Part No.</u>
Power Transformer	EP-612c
Output Transformer	EP-613c
Speaker Jack	EP-369a
Piano Jack	EP-372a
Record Jack	EP-372a
Fuse Holder	EP-378a
Fuse, 1 Amp. Slo-Blo	EP-379a
Set of Tubes	EP-616a
1-Tube, 5Y3GT	
2-Tube, 6V6GT	
1-Tube, 12AX7	
Set of Resistors	EP-1084a
1-1500 ohms, $\frac{1}{2}$ Watt	
1-6800 ohms, $\frac{1}{2}$ Watt	
1-18,000 ohms, $\frac{1}{2}$ Watt	
6-470 K ohms, $\frac{1}{2}$ Watt	
1-1.5 Meg., $\frac{1}{2}$ Watt	
1-22 Meg., $\frac{1}{2}$ Watt	
2-680 ohms, $\frac{1}{2}$ Watt	
1-22 K ohms, 2 Watts	
1-125 ohms, 7 Watts, Wire Wound	
Set of Capacitors	EP-1083a
1-Electrolytic, 40-15-10-25	EP-390a
1-Electrolytic, 25 MFD, 25 W.V.	EP-632a
1-Electrolytic, 8 MFD	EP-386a
1-.1 Ceramic, 600 Volt	
3-.001 Ceramic Disc. 500 Volt	
2-.02 Ceramic Disc. 500 Volt	
1-.0001 Ceramic Disc. 500 Volt	
1-.001 Ceramic Disc. 1600 Volt	
Tube Shield	EP-623a
Input Cable Assy.	EP-723b
Phono Input Plug	EP-205a

MODEL 700 WURLITZER ELECTRONIC PIANO

REED CHART

<u>Reed No.</u>	<u>Sect.</u>	<u>Note</u>	<u>Reed No.</u>	<u>Sect.</u>	<u>Note</u>
EP-586-13	Bass	A	EP-586-47	Lower	G
EP-586-14	"	A#		Middle	
EP-586-15	"	B	EP-586-48	"	G#
EP-586-16	"	C	EP-586-49	"	A
EP-586-17	"	C#	EP-586-50	"	A#
EP-586-18	"	D	EP-586-51	"	B
EP-586-19	"	D#	EP-586-52	"	C
EP-586-20	"	E	EP-586-53	"	C#
EP-586-21	"	F	EP-586-54	"	D
EP-586-22	"	F#	EP-586-55	Upper	D#
EP-586-23	"	G		Middle	
EP-586-24	"	G#	EP-586-56	"	E
EP-586-25	"	A	EP-586-57	"	F
EP-586-26	"	A#	EP-586-58	Lower	F#
EP-586-27	"	B		Treble	
EP-586-28	"	C	EP-586-59	"	G
EP-586-29	"	C#	EP-586-60	"	G#
EP-586-30	"	D	EP-586-61	"	A
EP-586-31	"	D#	EP-586-62	"	A#
EP-586-32	"	E	EP-586-63	Treble	B
EP-586-33	Lower	F	EP-586-64	"	C
	Middle		EP-586-65	"	C#
EP-586-34	"	F#	EP-586-66	"	D
EP-586-35	"	G	EP-586-67	"	D#
EP-586-36	"	G#	EP-586-68	"	E
EP-586-37	"	A	EP-586-69	"	F
EP-586-38	"	A#	EP-586-70	"	F#
EP-586-39	"	B	EP-586-71	"	G
EP-586-40	"	C	EP-586-72	"	G#
EP-586-41	"	C#	EP-586-73	"	A
EP-586-42	"	D	EP-586-74	"	A#
EP-586-43	"	D#	EP-586-75	"	B
EP-586-44	"	E	EP-586-76	"	C
EP-586-45	"	F			
EP-586-46	"	F#			

INDEX

-A-	<u>Page No.</u>
AC Cord	700-7
Action Regulation	700-11
Action, Shrinking	700-11
Amplifier	700-7-17-20-28
Amplifier, External	700-20
-B-	
Bar	700-11
(Also Page 7, Model 112 section, and Page 120-10 Model 120 section.)	
Bench Dimensions	700-2
-C-	
Cables	700-6-7
Capstan Adjustment	700-12
Center Pin Replacement (Page 16, Piano Service Manual)	
Claims, Filing of (Page 26, Piano Service Manual, and Page 700-21)	
Conclusion, (Page 16, Model 112 Section)	
Cross Section of Model 700 Electronic Piano .	700-9
-D-	
Damper Adjustment	700-18
Diagram of Wurlitzer Electronic Piano	700-9
Dimensions	700-2
-E-	
Earphones	700-20
External Amplification ...	700-20
External Speaker	700-20
-F-	
Finish, Care of (Page 12, Model 112 Section)	
Fuse	700-7
-H-	
Hammers, Burning	700-19
Hammers, Blocking	700-19
Hammers, Let-Off (see Regulating Procedure Pages 120-11-12-13)	
-I-	
Introduction	700-1

-J-	<u>Page No.</u>
Jacks	700-21
-K-	
Keys, Cleaning (Page 12, Model 112 Section)	
Keys, Damaged (Page 7 Piano Service Manual)	
Key Depth	700-12
Keys, Easing (Page 4, Piano Service Manual)	
Keys, Leveling (Page 11, Model 112 Section)	
Keys, Spacing (Page 7, Piano Service Manual)	
-L-	
Let-Off Adjustment	700-16
-P-	
Preparation of Model 700 For Sale	700-3
Pick-Up (Page 7, Model 112 Section)	
Pilot Light	700-7
Parts List	700-25-26-27-28-29
-R-	
Range (Page 7 Model 112 Section)	
Record Player	700-21
Reeds	700-19-29
-S-	
Schematic Diagram of:	
Control Panel	700-22
Amplifier	700-23
Service Department	700-21
Specifications	700-2
Spoon Adjustment	700-17
Striking Point	700-18
Switch	700-7
-T-	
Tone Principle (Page 7, Model 112 Section)	
Touch (Regulating Procedure).....	700-12-13-16
Tubes	700-6-24
-V-	
Voltages	700-2-7-22-23
Volume Control	700-2-7-22

N O T E S

This document was digitized by Tropical Fish in order to assist in the restoration of vintage Wurlitzer electronic pianos.

For your convenience, the full text of this document is searchable. Find high-res versions of just the schematics (as well as additional service manuals) at tropicalfishvintage.com/schematics

Questions & comments: info@tropicalfishvintage.com

